

BIOTRITURATORE MOTORE A BENZINA 20 HP

BIO 10-B



ORIGINAL MADE IN ITALY | zanon.it

POWERED by
HONDA

Maniglione di sicurezza
Safety handle
Sicherheitsgriff
Manilla de seguridad
Arceau de sécurité



L'apparecchiatura è conforme ai requisiti richiesti dalla direttiva 2000/14/CE per la limitazione del rumore ambientale.

The equipment complies with the requirements of Directive 2000/14/EC for the limitation of environmental noise.

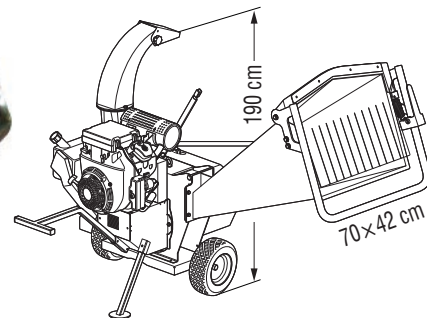

BIO 10-B	20 HP Petrol engine
BIO 10-B	Motor-gasoline 20 HP
BIO 10-B	Motor de gasolina 20 HP
BIO 10-B	Moteur à essence 20 HP

MOD	HP	kg	cm	
mod.	cod.	HP	kg	cm
BIO 10-B *	1002388	HP 20 HONDA GX 630	320	200×112×190

* Avviamento elettrico - Electric starter - Elektrostart - Arranque eléctrico - Démarrage électrique

MOD	cm	m ³ /h	rpm/min	nr (type)	nr	nr	nr
mod.	cm	m ³ /h	rpm/min	nr (type)	nr	nr	nr
BIO 10-B	8,5	6 - 5	2850	2 (XPA 1082)	12	3	1

Di serie	Standard equipment	Serienmässig	Estándar	De série
<ul style="list-style-type: none"> • Avviamento elettrico • Ruote per spostamento • Tubo di scarico registrabile • Filtro olio a cartuccia • Frizione centrifuga per stacco automatico • Avanzamento rullo regolabile idraulicamente • Protezioni antinfortunistiche conformi alla normativa CE 	<ul style="list-style-type: none"> • Electric start • Transfer wheels • Adjustable discharge pipe • Oil cartridge filter • Centrifugal clutch for automatic detachment • Adjustable working-speed controlled by hydraulic system • Protective equipment as per EC safety rules 	<ul style="list-style-type: none"> • Elektrostart • Satz Hinterräder • Regulierbares Entladungsrohr • Ölfilterkartusche • Fliehkraftkupplung für automatische Absonderung • Hydraulisch einstellbarer Walzenvorschub • Unfallschutz nach EU-Vorschriften 	<ul style="list-style-type: none"> • Arranque eléctrico • Ruedas de transporte • Tubo de descarga orientable • Filtro de aceite (cartucho) • Embrague centrifugo para desacoplamiento automático • Rodillo de alimentación con regulación hidráulico. • Protecciones de seguridad de acuerdo con la norma CE 	<ul style="list-style-type: none"> • Démarrage électrique • Roues de déplacement • Tuyau d'échappement réglable • Filtre à huile à cartouche • Friction centrifuge pour décrochage automatique • Avancement rouleau réglable hydrauliquement • Protections contre les accidents aux normes CE

cod.	Ricambi	Spare parts	Ersatzteile	Recambios	Pièces de rechange
5023072	Motore orbitale	Orbital motor	Motor augenhöhlen	Motor orbital	Motor orbitaire
5023087	Motore HONDA 20 HP avv. elettrico	Motor HONDA 20 HP elec. starter	Motor HONDA 20 HP Elektrostart	Motor HONDA 20 HP arr. eléctrico	Moteur HONDA 20 HP dém. élect.
5210289	Lama	Blade	Blatt	Cuchilla	Lames
5210290	Controlama	Counterblade	Gegenschlägel	Contracuchilla	Contre-lames
5226590	Martello	Hammer	Hammer	Martillo	Marteau
5353113	Frizione BIO 10	Clutch BIO 10	Kupplung BIO 10	Fricción BIO 10	Embrayage BIO 10
5354059	Cinghia XPA 1082	Belt XPA 1082	Riemen XPA 1082	Correa XPA 1082	Courroie XPA 1082
5411020	Ruota	Wheel	Rad	Rueda	Roue
5433015	Cartuccia filtro olio	Cartridge filter oil	Patrine Filterölfilter	Cartucho filtro aceite	Huile du filtre de la cartouche
5433014	Filtro olio completo	Complete filter oil	Filterölfilter	Filtro aceite completo	Huile du filtre complète
2131005	Accoppiamento rotore pompa	Attachment rotor-pump	Rotor befestigungs pumpe	Conexión bomba / motor	Attelage pompe / rotor