

SEMI-MOUNTED REVERSIBLE PLOUGH **TITAN 18**





OUR D
YOUR



PERFORMANCE IN A NEW DIMENSION

The concept

The demands placed on modern semi-mounted reversible ploughs are becoming ever more stringent as farms continue to increase in size. In view of various factors such as yield potential, precipitation and different crop rotations, farm managers still rely on powerful and efficient plough technology.

Handling, quality of work and increase in productivity play an important role. With the **Titan 18**, LEMKEN fulfils farmers' high demands.

The **Titan 18** semi-mounted reversible ploughs are used exclusively as onland versions to protect soils.

The Titan 18 semi-mounted reversible plough

The working width of the LEMKEN **Titan 18** can be adjusted to one of four settings, from 33 to 50 cm per plough body. It is available with nine to thirteen furrows in working widths of 297 cm to 650 cm, also with the new OptiStone hydraulic overload protection.

The Titan 18 V semi-mounted reversible plough

The LEMKEN **Titan 18 V** offers infinitely variable hydraulic working width adjustment from 30 to 55 cm per plough body. It is available with nine to thirteen furrows in working widths of 270 cm to 715 cm, also with the new OptiStone hydraulic overload protection.

Requirement profiles

- These ploughs are exceptionally manoeuvrable for rapid turning on narrow headlands and maximum area output.
- The hydraulic cutting width adjustment allows a quick and convenient response to variable soil and weather conditions.
- Increasing tractive outputs on tractors place particularly high demands on the plough strength with larger working widths.
- The skimmers can be easily and quickly adjusted without tools.
- Safe road transport without overloading the tractor.
- Longer service life of the wear parts results in lower plough costs.
- The onland turnover device (optionally) allows the implement to be swung in before rotation and supports outside tractor widths of up to 4.60 m.
- Can be combined with FlexPack for direct reconsolidation.

**DRIVING FORCE:
SUCCESS!**

ROBUST, RELIABLE, BIG AND AGILE



The stable headstock

The height of the end-to-end suspended Category III or IV drawbar is easy to adjust. It absorbs stronger impact loads, relieving the tractor and headstock.

The turning axle is surface hardened, mounted on tapered rollers and easy to lubricate. This means high strength and a long service life.



The straightforward draw point adjustment

The height of the horizontal draw point is easily adjusted simply by repositioning a pin. This provides for a precise load transfer to the rear axle of the tractor.

When using crawler tracks, the draw point is set very low to ensure that even loads are applied to the tracks.

Slip is minimised on all tractors through the optimal transfer of tractive forces.



The reliable turnover device

Two telescope cylinders turn the plough powerfully and smoothly by 180 degrees. Yet the system only requires low hydraulic working pressure. The precise angle adjustment is performed separately for each side with adjustment bolts.

The sturdy stands allow the plough to be easily detached when in transport position and parked space saving in the implement shed.

THE CONNECTION



Not permitted within the EU!

Coupling carriage for tractors without three-point hydraulics

If there is no three-point linkage available on the tractor for attachment, all LEMKEN **Titan 18** ploughs can also be equipped with a **coupling carriage**. The coupling carriage then assumes the lifting function that is otherwise performed by the three-point linkage. Due to the width of more than 3 m and length of more than 18 m, the transport of the entire implement on public roads is not permitted.



Traction booster (optional)

Titan 18 ploughs can optionally be fitted with a traction booster. An additional hydraulic cylinder transfers weight to the tractor's rear axle. This enhances the tractor's traction.

As soon as the hydraulic system raises the plough frame via the carriage/middle section, the pressure in the traction booster is automatically reduced. This ensures that full tractor stability is

maintained at all times. As soon as the carriage/middle section is lowered, pressure is automatically increased again.

ALWAYS THE **RIGHT BEARING**



Continuously variable working width

The frame plates supporting the leg brackets are bolted to the frame. This provides outstanding stability, increased durability and a high degree of engineering precision. The pivots for the leg brackets, which are supported next to the frame, are located close to the plough body. This reduces strain on the bearings and other components. The working width is continuously adjustable via a double-acting hydraulic cylinder.

The variable bearing

The main bearing pin of the swivel bracket has tension bushings and is locked against rotation with the frame plates. The swivel bracket has crimped flange bushings. The two bushes of the cutting width adjustment run within each other for a long service life. Each component can be replaced separately if worn.

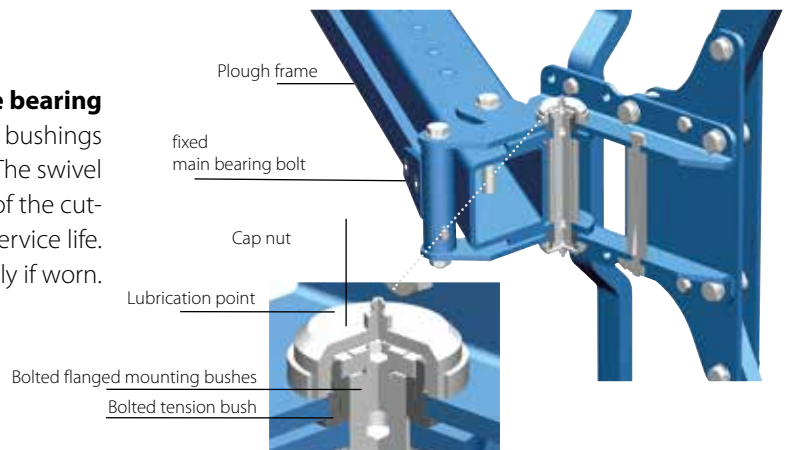

The adjustment brackets

The fixed bolt connection between the adjustment brackets and frame provides outstanding stability, reliable durability and a high degree of engineering precision. Once the central bolt has been loosened, four working widths between 33 and 50 cm can be set (depending on interbody clearance). Skimmers and disc coulters are adjusted automatically.

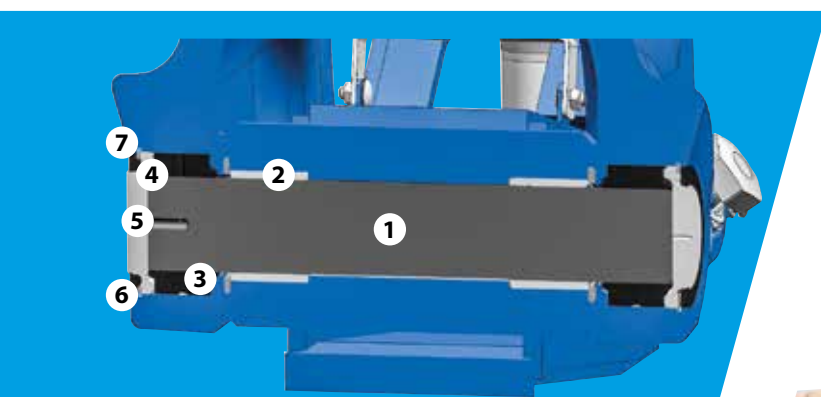

- 1 Bolt
- 2 Bush
- 3 Spherical plain bearing
- 4 O-ring
- 5 Cap
- 6 Circlip
- 7 Gasket

Superior safety and reliability

All main bearings feature highly robust spherical plain bearings. These have a particularly long service life and ensure high reliability of operation.



DETAILS FOR ALL CONDITIONS



Front furrow width adjustment

The front furrow width or the distance of the tractor to the furrow edge can be adjusted via a turnbuckle or hydraulically from the driver's seat.



The articulated frame

The **Titan 18** semi-mounted reversible plough is characterised by its perfect ground adaptation, even on undulating terrain. The frame joint between the front and the rear plough sections enables bending both in the working depth and in the direction of travel.

The bearing pin is mounted in surface hardened guiding elements. For the turning procedure, the frame joint is automatically locked with a double-acting cylinder.

The frame joint precisely maintains the working depth over the whole width of the plough.



Uniform working depth

The working depth is precisely adjusted in fine steps without tools using pins both on the carriage and on the rear support wheel.

The rear support wheel is automatically put into its working position when the plough is set into the ground. This prevents undesirable swivelling of the wheel towards the front when ploughing on uneven terrain.

ONLAND OPERATION TO PROTECT THE SOIL



The larger tractors required for operating **Titan** ploughs are generally equipped with wider tyres with 710 mm, 800 mm or even wider treads, with dual wheels or crawler tracks. There is not enough space for these tyres in the furrows, resulting in harmful soil compaction when driving across loosened soils and along furrow edges. Dual wheels or crawler tracks always require onland use. That's why the Titan is specially designed for online use. Thanks to the increasing use of GPS guidance systems on tractors, almost every large farm is now able to benefit from online ploughing.

With working widths of up to 7.15 m, the **Titan** ploughs are optimally suited for high area outputs. The onland turnover device ensures precise, safe plough rotation and protects both the tractor and the plough. This optionally allows the implement to be swung in before rotation and supports outside tractor widths of up to 4.60 m.

OPERATING COMFORT

The plough at the headlands

At the headlands, the plough is first lifted at the front, and then at the back. Next, the rear plough frame is lifted and the articulated frame is locked. Finally, the plough is reversed. The time-controlled lifting and lowering significantly reduces the operational triangle at the headland, which is otherwise very large with big ploughs. For optimal operation of the **Titan 18** with electronic plough control, it is advantageous to have load-sensing hydraulics on the tractor.



The rear plough frame

In addition to the level adaptation of the plough in working position and the lowering of the front plough frame, the articulated frame also enables separate lifting of the rear plough frame using the electronic plough control. This makes it possible, for example, to plough with 12 furrows in one direction, and only 8 in the other direction.



The cost-effective plough bodies

The Dural body

The frog of the Dural body is tempered and extremely strong. The pitch of the plough bodies is adjustable to ensure consistently good penetration of the plough into the soil. The smooth transition from the share to the mouldboard and the low-resistance shape make the plough even easier to pull. The mouldboards made of hardened boron steel are low-wear and have no bolts in the main wearing zones. The extra large mouldboard shin can be individually replaced.



The slatted body

The slats of the slatted body are made of thick, completely hardened boron steel and can be individually replaced. Slatted bodies and conventional mouldboards are based on the same basic body. The attachment bolts are deeply sunk to guarantee secure fixing of the slats for an extremely long service life. High material density and firm attachment guarantee resistance to wear and breakage. The overlapping design prevents roots or foreign objects from catching. The wear zones of the share wings are significantly larger than with conventional shares.



Body assembly

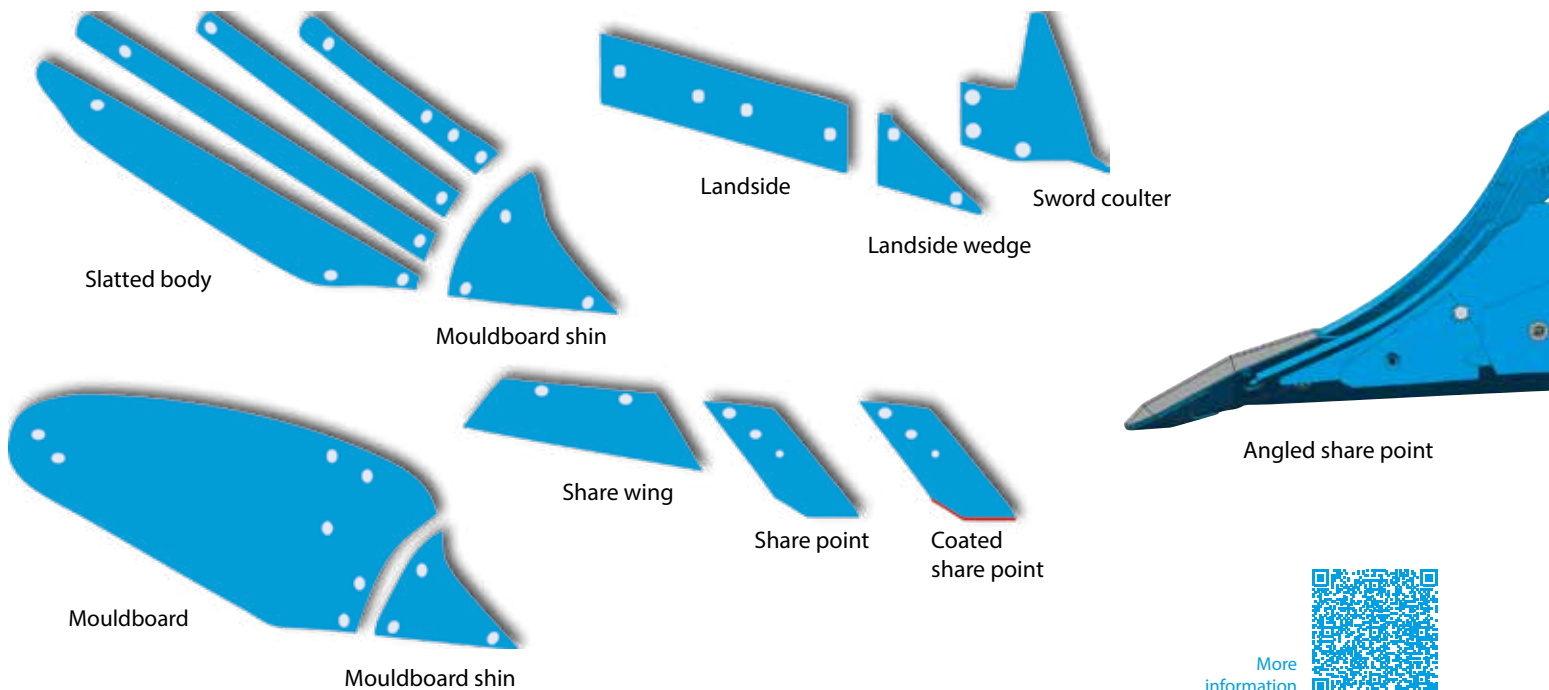

The material, cross section and shape of the exchangeable **share points** guarantee low wear and good penetration into the soil. The extra wide **landslides** with a large surface area provide better plough guidance. They can be turned four times.

A much larger proportion of wearing material surface enables an optimal utilisation of the **sword coulter**. The attachment lies in the shadow of the cutting tools and is therefore protected from wear and damage. The cutting edge is slanted to the back and open to the top so that stones and roots cannot get stuck.

A special hard metal coating on the **share point** ensures a long service life and much greater cost efficiency. The **share point** is coated from the bottom on one side. This creates a self-sharpening effect.



DuraMaxx - the perfect plough body

The DuraMaxx plough body represents a radically new approach that increases service life by up to 150% whilst reducing set-up times by up to 80%. All DuraMaxx components are

manufactured from much harder steel than previous bodies. The material is no longer weakened by drilling and punching holes in it.

Mouldboards and slats are fully supported by the frog. They are no longer a load-bearing part of the plough body. Their sole function is to turn over the soil.

This means they can wear out to a higher degree without the risk of snapping due to soil forces.

ALWAYS WELL PREPARED

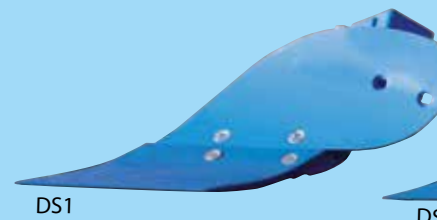

Skimmers for blockage-free ploughing

- Skimmers of different share lengths ensure blockage-free ploughing even in difficult conditions.
- The special shape of the shares minimises wear and increases their service life, while creating an outstanding soil flow.
- The specially shaped mouldboard separates the organic matter and neatly deposits it.
- Plastic mouldboards are available for sticky soils and in soil conditions where only little pressure applies on the skimmer.



Tool-less skimmer adjustment

The working depth and angle are adjusted independently of each other without requiring tools. The working depth can be continuously adjusted via a pin on the flat stalk. This allows all skimmers on the plough to be adjusted evenly without repeated checks and readjustments. This does not affect the throw angle.



No skimmer distortion

The Titan version with skimmers features robust flat stalks that are connected to the frame via two bolts. The flat stalk prevents skimmer distortion. It can be easily removed for ploughing without skimmers.



Trashboards for blockage-free work

The trashboards are fitted directly to the mouldboards and are fully adjustable. They enable blockage-free work and clean incorporation even on extreme surface residue. For sticky soils, trashboards are also available in plastic.

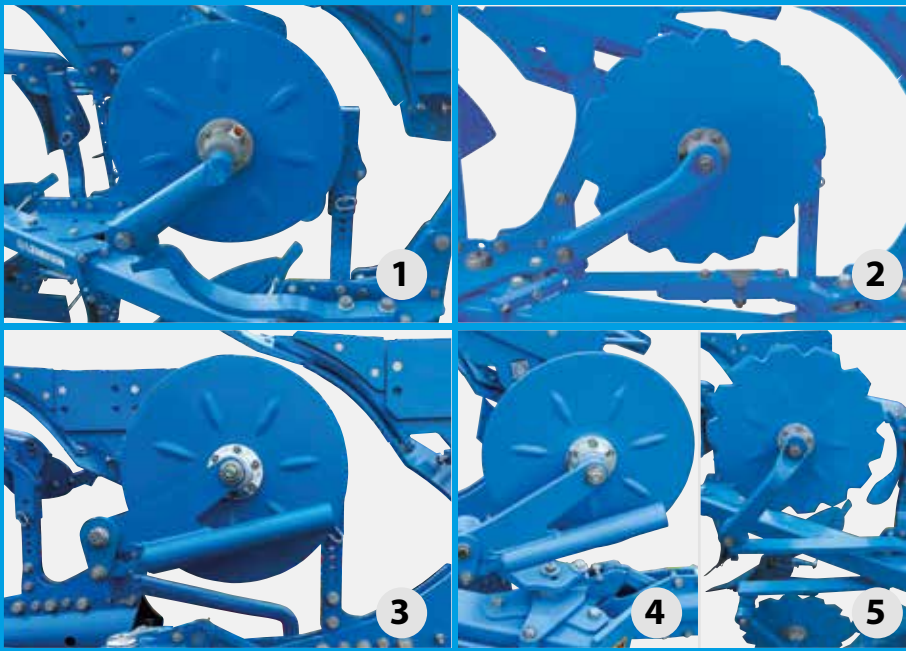

The **disc coulters** are available in a variety of sizes and mounting positions:

- 1) **Ø 500 mm**, next to skimmers
- 2) **Ø 590 mm**, in front of/next to skimmers, adjustable
- 3) **Ø 500 mm**, on the U segment next to skimmers
- 4) **Ø 500 mm**, suspended in front of skimmers
- 5) All diameters optionally in serrated versions

The disc coulters

The smooth disc coulters are corrugated at the sides. This provides a positive drive even when breaking up high amounts of organic material. The depth is adjusted through vertical swivelling of the disc coulters arms, which can be fastened with a bolt in the indentation. The smooth bearings run alongside the unploughed land and are double-sealed against dirt ingress.

Subsoiler for effective loosening

The specially shaped subsoiler delivers a particularly good loosening effect. The subsoiler depth can be adjusted without tools, and the subsoiler can also simply be removed without requiring tools, if necessary. All wear parts can be individually replaced. The stalk guard prevents wear on the stalk.

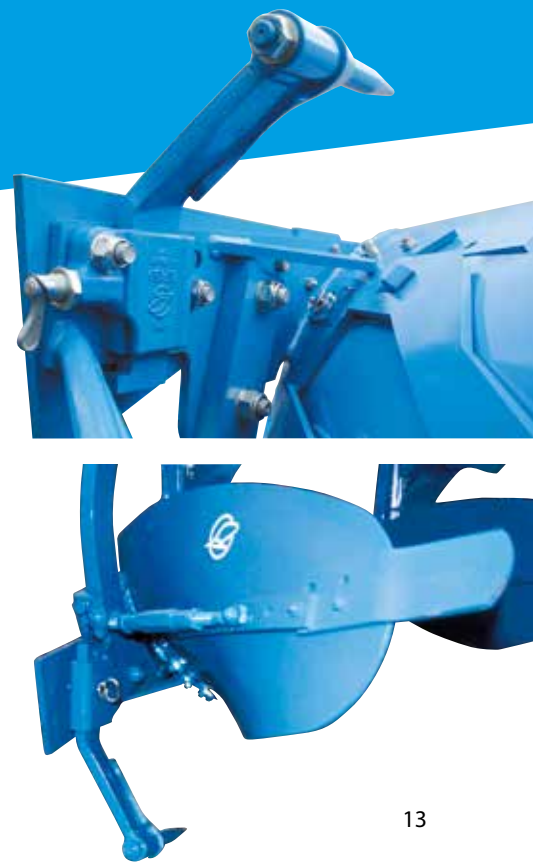

GOOD AND SAFE ON FIELDS AND ROADS



When it gets a bit late

Four LED work lights ensure good visibility in the dark





The carriage

The large transport wheels minimise soil compaction during ploughing and ensure the required safety for road transport. The carriage axle is equipped with 400/70 R 20 tyres. For quick and safe road transport, the **Titan 18** is turned to the middle position and locked with two stop valves. It can then be safely towed behind the tractor just like any single-axle trailer. The system efficiently relieves mechanical strain on both tractor and plough.



WITH OPTISTONE HYDRAULIC OVER **VERSATILE AND CONVENIENT**

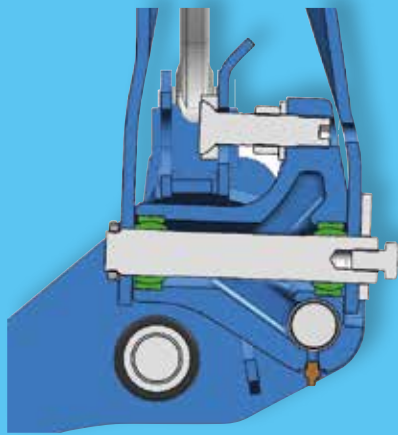

Superior precision and operational reliability

The closed system of highly stable leg plates is reliably protected against dirt and foreign objects. A newly designed swivel bracket delivers high horizontal and vertical trigger forces while ensuring stable plough control. The system is supported in highly stable, easily accessible radial spherical plain bearings. The plough body is firmly connected to the three-dimensional bearing point – a clear advantage compared to the overload protection systems with four-point suspension commonly found on the market.

- Precise body alignment
- Stable and safe plough control
- No unhitching of the element
- Easy maintenance for a long service life and high reliability of operation



OVERLOAD PROTECTION:

High vertical and horizontal trigger forces

The OptiStone overload protection is based on a new swivel bracket with high trigger and re-entry forces to ensure that the system is triggered softly and smoothly when an obstacle is encountered. This protects both tractor and plough.

The overload element is easily able to deflect vertically up to 37 cm and horizontally up to 20 cm at the same time. This provides for a sufficiently large range of deflection to ensure consistently disruption-free work, even with deep ploughing.

The high trigger forces can be conveniently and continuously adjusted to variable conditions from the tractor seat.



TITAN 18

TECHNICAL SPECIFICATIONS

Designation	Working width per furrow approx. cm	Interbody clearance cm	Number of furrows	Weight approx. kg
Titan 18				
Titan 18 6+3 / 100	33, 38, 44, 50	100	6+3	5,220
Titan 18 6+3+1 / 100	33, 38, 44, 50	100	6+3+1	5,665
Titan 18 6+4 / 100	33, 38, 44, 50	100	6+4	5,665
Titan 18 6+4+1 / 100	33, 38, 44, 50	100	6+4+1	6,110
Titan 18 7+4 / 100	33, 38, 44, 50	100	7+4	6,110
Titan 18 7+4+1 / 100	33, 38, 44, 50	100	7+4+1	6,556
Titan 18 8+4 / 100	33, 38, 44, 50	100	8+4	6,556
Titan 18 U				
Titan 18 U 6+3 / 100	33, 38, 44, 50	100	6+3	5,823
Titan 18 U 6+3+1 / 100	33, 38, 44, 50	100	6+3+1	6,335
Titan 18 U 7+3 / 100	33, 38, 44, 50	100	7+3	6,335
Titan 18 U 7+3+1 / 100	33, 38, 44, 50	100	7+3+1	6,847
Titan 18 U 8+3 / 100	33, 38, 44, 50	100	8+3	6,847
Titan 18 U 8+3+1 / 100	33, 38, 44, 50	100	8+3+1	7,293
Titan 18 V				
Titan 18 V 6+3 / 100	30 - 55	100	6+3	5,440
Titan 18 V 6+3+1 / 100	30 - 55	100	6+3+1	5,910
Titan 18 V 6+4 / 100	30 - 55	100	6+4	5,910
Titan 18 V 6+4+1 / 100	30 - 55	100	6+4+1	6,380
Titan 18 V 7+4 / 100	30 - 55	100	7+4	6,380
Titan 18 V 7+4+1 / 100	30 - 55	100	7+4+1	6,850
Titan 18 V 8+4 / 100	30 - 55	100	8+4	6,850
Titan 18 V 8+4+1 / 100	30 - 55	100	8+4+1	7,320
Titan 18 V U				
Titan 18 V U 6+3 / 100	30 - 55	100	6+3	6,043
Titan 18 V U 6+3+1 / 100	30 - 55	100	6+3+1	6,580
Titan 18 V U 7+3 / 100	30 - 55	100	7+3	6,580
Titan 18 V U 7+3+1 / 100	30 - 55	100	7+3+1	7,117
Titan 18 V U 8+3 / 100	30 - 55	100	8+3	7,117
Titan 18 V U 8+3+1 / 100	30 - 55	100	8+3+1	7,654

WE'RE **HERE FOR YOU**

Supplying high-quality original wear parts

Our original LEMKEN wear parts ensure that your LEMKEN machine stays what it is: the genuine product. Whichever machine you need a spare part for, we ensure that the original parts are always available for all LEMKEN machines. Not only in the short term, but for years to come.

Delivering spare parts speedily

The right parts at the right time in the right place — this is how a reliable replacement parts service should operate. Our professional logistics handling service ensures we can supply a wide range of replacement parts at speed, whenever and wherever they are needed.



OUR DRIVING FORCE:
YOUR SUCCESS!



LEMKEN GmbH & Co. KG
Weseler Strasse 5
46519 Alpen, Germany
Tel. +49 2802 81-0
Fax +49 2802 81-220
info@lemken.com
lemken.com

Your specialist LEMKEN dealer:



H-7522 Kaposújlak, 095/3 hrsz.
Tel: +36-82/713-274, +36-30/336-9804
E-mail: bedenek@kapos-net.hu
WEB: www.bedenek.hu