

SUBSOILERS



SUBSOILERS: INNOVATION MADE PERFECT

OUR HISTORY

VITTORIO PEGORARO

In the years immediately after the First World War, Vittorio Pegoraro drew on his in-depth knowledge of farmers' needs to build his first agricultural machinery with intelligent, innovative solutions.

Initially, everything was designed and built by hand in the small workshop next door to his home, but thanks to his excellent ideas and high construction quality, very popular with the clientele, Vittorio soon became well known in the agricultural mechanisation sector.

In the '70s, the first prototype subsoilers began to appear on the Italian market. Signifying an improvement in farming methods and economic returns, subsoiling soon attracted farmers' interest.

Grasping the subsoiler's importance at once, with the aid of his sons Vittorio started in-depth research to optimise it, and offered the market the first subsoiler with bolted modular frame. This lightweight but very rugged machine had a crucial new feature: the shear bolt.



This solution, essential to prevent the problem of shank failure in heavy-duty situations, is still used by most constructors today.

These subsoilers were quickly successful throughout Europe, and Vittorio and his sons, constantly working to support farmers, came up with another innovation: franter rollers. Initially introduced to support the subsoiler, the two rollers at the rear perform crucial initial surface tillage, for optimal soil levelling. The effective job they do also reduces the amount of subsequent tillage required, and is a major aid in burying crop residues.

Nowadays, the features introduced to subsoilers by Vittorio Pegoraro are viewed as essential and are used the world over to ensure optimal results.



WE DEVELOPED A COMPLETE SYSTEM, BECAUSE HAVING THE BEST STEEL ISN'T ENOUGH FOR US.

The "ALPEGO INSIDE" label, seen on all our machines, certifies the **exceptional quality** of Alpego products. A perfect combination of **top quality raw materials**, a **sustainable painting process** and **certified welding**; all to guarantee **exceptional lifetime and lasting quality**.

HIGH STRENGTH STEEL

All Alpego machines use **the best steel to reduce the weight and increase performance**, fully optimising both consumption and running costs. This also has a huge impact on environmental sustainability.

CERTIFIED WELDING

The outstanding useful life of Alpego structural components has been guaranteed for over twenty years by effective **welding according to standardised processes certified by the Italian Institute of Welding**.

ECO PAINTING

In Europe, this unique system allows **every component to be painted according to the most suitable process, while protecting the environment**. Our water-based and powder paints **produce no VOC** (volatile organic compounds) emissions.

Benefits of subsoiling

Subsoiling cuts costs compared to conventional tillage



Alpego subsoilers perform various farming functions, with multiple benefits.

Mattia Trevini
Agronomist



Why choose Alpego subsoilers?

Three solutions, one machine

The Alpego range of subsoilers was the first to introduce a wide range of tools for different types of tillage. This versatility enables the use of various cultivation techniques.



CONVENTIONAL TILLAGE

ALPEGO SUBSOILERS



All conventional tillage methods require longer working times and high fuel consumption and have drawbacks in agronomic terms: limited water drainage, reduction in capillarity, loss of yield and thus lower earnings.

Subsoiling is a tillage technique that requires shorter working times, and therefore saves fuel. In agronomic terms, subsoiling improves water drainage, enhances capillarity, and provides multiple benefits to crops with higher yields, meaning higher earnings.

CRAKER SHANK

The curved shank penetrates the ground gradually, reducing the draft force required, and improves mixing of the soil both in depth and on the surface, by overturning the clods.

CLOD-SHATTERING FINS

Accessory designed by Alpego with adjustable lateral fins to enable better crumbling and turnover of the topsoil. They also effectively cut the root systems of weeds or crop residues.

DEK PLOUGHSHARE

Dek ploughshares are designed to provide surface tillage even with crop residues present. Their conformation ensures effective tillage across the entire width of the machine and is ideal for depths of up to 15 cm.

A complete range for every need

The right subsoiler for every situation



The Alpego range of subsoilers benefits from high quality standards that guarantee outstanding performances and reliability even in the heaviest duty and teamed with high-power tractors. Constructed entirely from high strength steels, available with widths up to 5 metres and equipped with various solutions and accessories, they are able to meet all farmers' different needs.



Alpego subsoilers are designed for high speed operation, in what is known as "Velocitilling". The many benefits include shorter working times, impressive fuel savings and a high quality job.

CRAKER K-DYNO

Rigid mechanical subsoiler
HP 75-130
Page 16



CRAKER K-EVO

Rigid mechanical subsoiler
HP 130-220
Page 17



MEGA CRAKER K-EXTREME

Folding mechanical subsoiler
HP 250-500
Pages 22-23



CRAKER K-FORCE

Rigid mechanical subsoiler
HP 180-350
Page 18



SKAT S1

Hydro-pneumatic subsoiler
HP 130-250
Page 28



SKAT S2

Hydro-pneumatic subsoiler
HP 220-400
Page 29



CRAKER technical characteristics

Details that make the difference

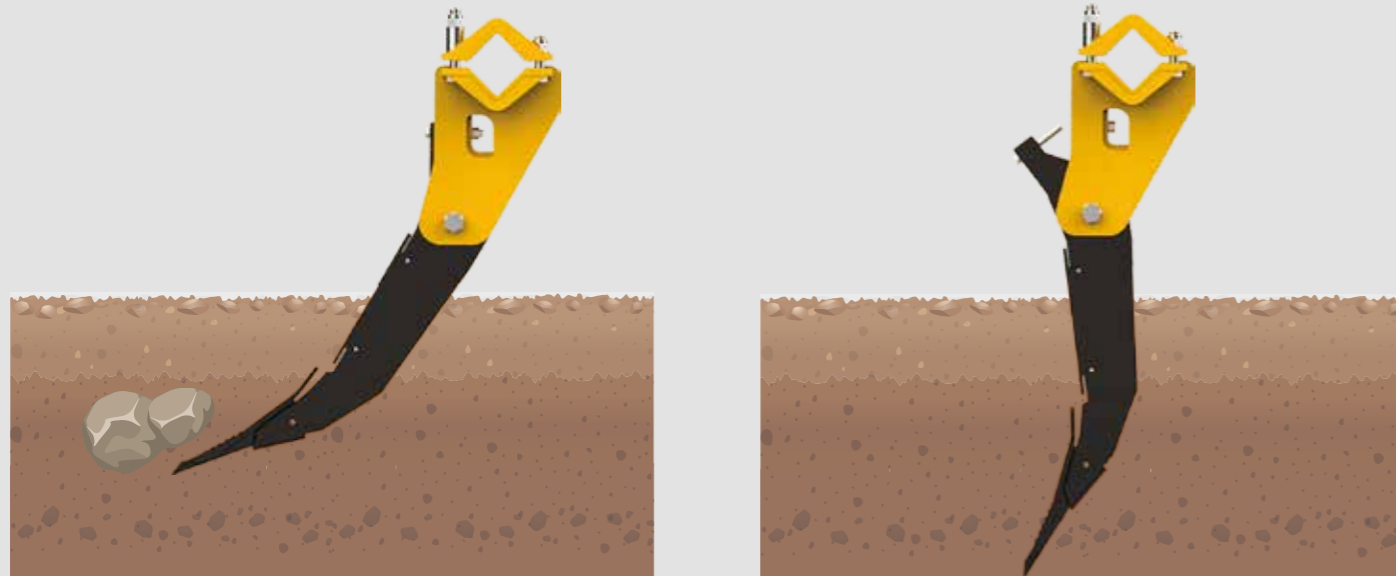

MECHANICAL SHEAR BOLT

Safety solution introduced by Alpego, a mechanical safety shear bolt fitted on every shank; if the shank hits an obstacle, the bolt shears, protecting the machine structure.



BOLTED FRAME

High performance all-bolted frame. New side plates design for faster roller mounting. The high strength steel used provides the optimal trade-off between light weight and resistance. Standard on models: K-DYNO / K-EVO / K-FORCE



SHANK MOUNTING

Clamps are diagonally fitted to reduce stresses on bolts, minimising the number of bolt failures. Standard on models: K-DYNO / K-EVO / K-FORCE / K-EXTREME



CLAMP SHOCK ABSORBER SYSTEM

The combination of a spacer with a longer screw helps to increase and exploit all the elasticity, reducing the risk of failure. Standard on models: K-EVO / K-FORCE / K-EXTREME

New technical features

Technique and design for the new models

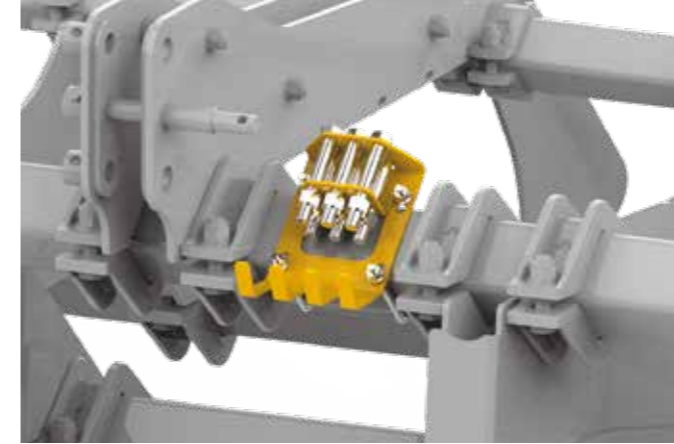

BOLT HOLDER

Spare bolt holder integrated in frame. (STANDARD)

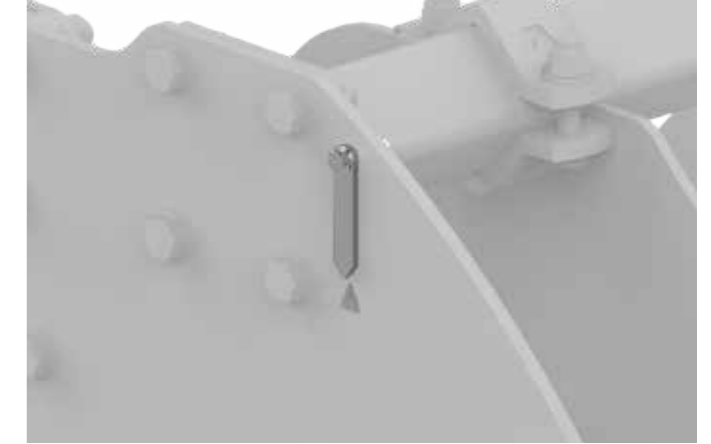

ANGLE GAUGE

Angle gauge integrated in frame. Its internal and external positioning ensures visibility from the ground and from the driving seat. (STANDARD)



DEPTH GAUGE

Roller depth gauge clearly visible from the tractor driving seat. Available as standard on all hydraulically adjusted Franter rollers and on the modular parallelogram kit. (STANDARD)



TELESCOPIC CLOD-RESTRICTING SIDE BOARDS

Hydraulically controlled clod-restricting telescopic side boards, designed to make transport easier, width-adjustable and easily disabled when not required, for simple jobs with no problems for operator safety. (OPTIONAL)

ALFAST

Alpego Fast System



Interchangeability

Quick, easy accessory changes

Alpego has always offered different accessories for different technical and farming solutions. With the ALFAST system, machines can be customised for all working conditions in just a few minutes, by replacing the standard ploughshare or shank guard with other accessories.

LOCKED



Reinforced shanks and ploughshares with exclusive ALFAST system

Alpego introduces an innovative ultra-fast ploughshare and accessory replacement system. With ALFAST, all you need is a hammer. No need to remove pins or screws. The patented system consists of a clip which moves to free or lock the accessory on the shank.

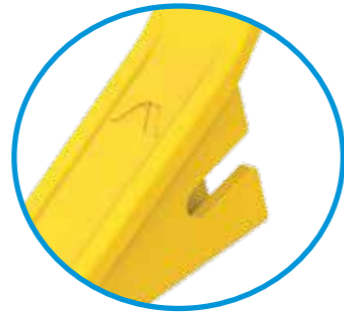

RELEASE

LOCK

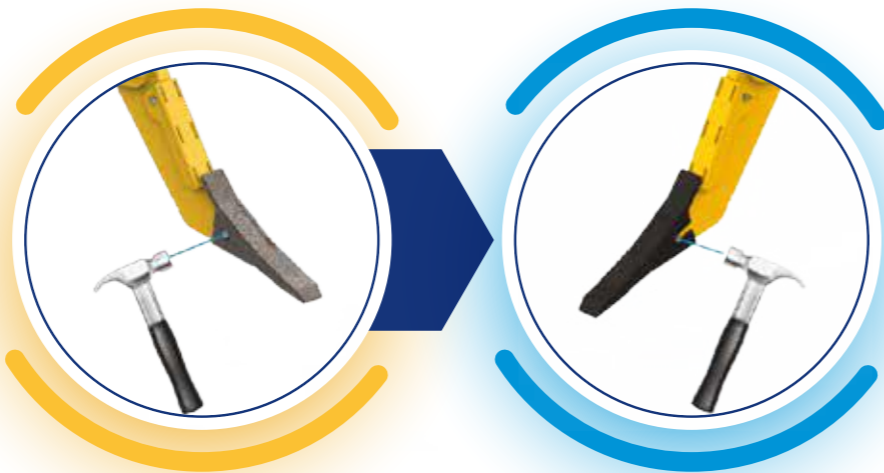

RELEASED

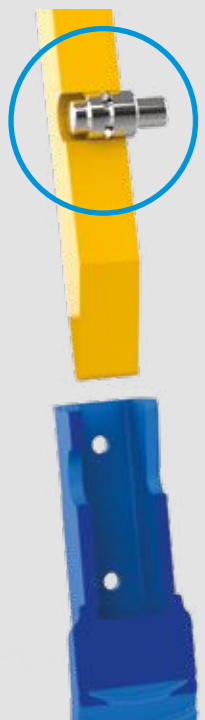

STANDARD

OPTIONAL

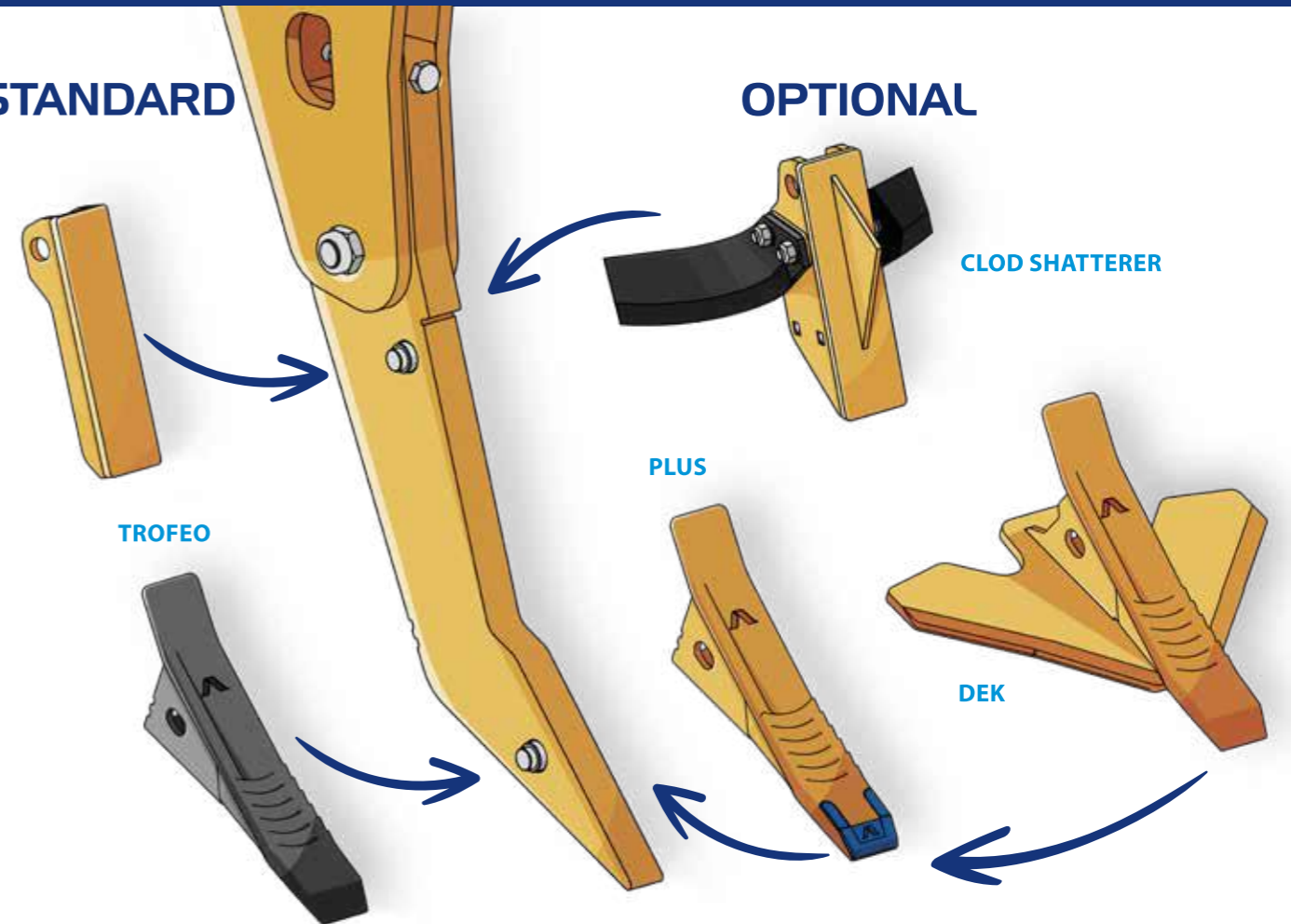

The advantages of the new ALFAST DEK system

The new DEK system consists of the TROFEO DEK ploughshare coupled to the DEK fin.

The coupled or single use of the two elements allows the operator to change operations in real time.

WHAT YOU NEED:

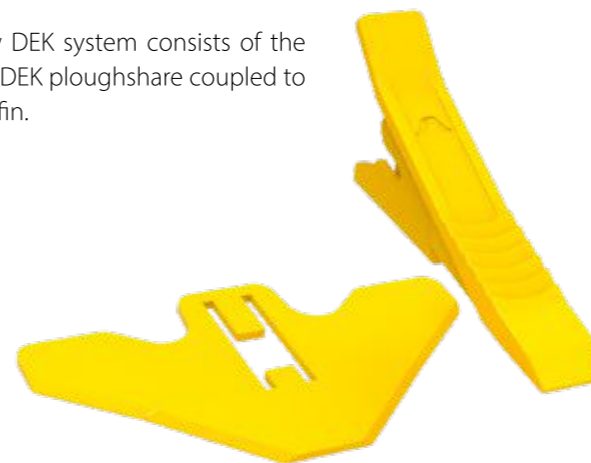
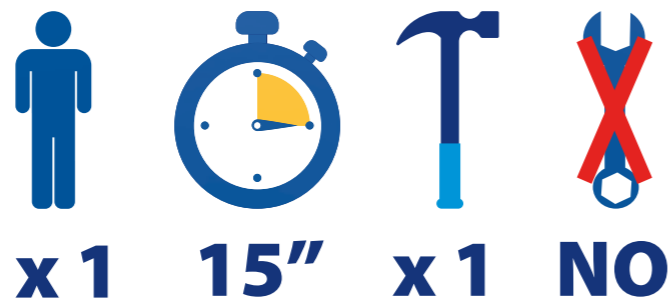

The advantage of this modular system is that the two elements can be reset separately.

Franter Rollers

Essential for cutting subsequent tillage needs

Franter rollers, conceived and introduced onto the market by Alpego, provide crucial initial surface tillage, for optimal soil levelling. The combined work of the two toothed rollers reduces the amount of subsequent tillage required, and is a major aid in burying crop residues.



ALTERNATIVE ROLLERS:

1 MODULAR HYDRAULIC PARALLELOGRAM KIT

Alpego has designed the modular parallelogram kit enabling quick changing of roller type. With this accessory, the machine is extremely versatile and suitable for all conditions.

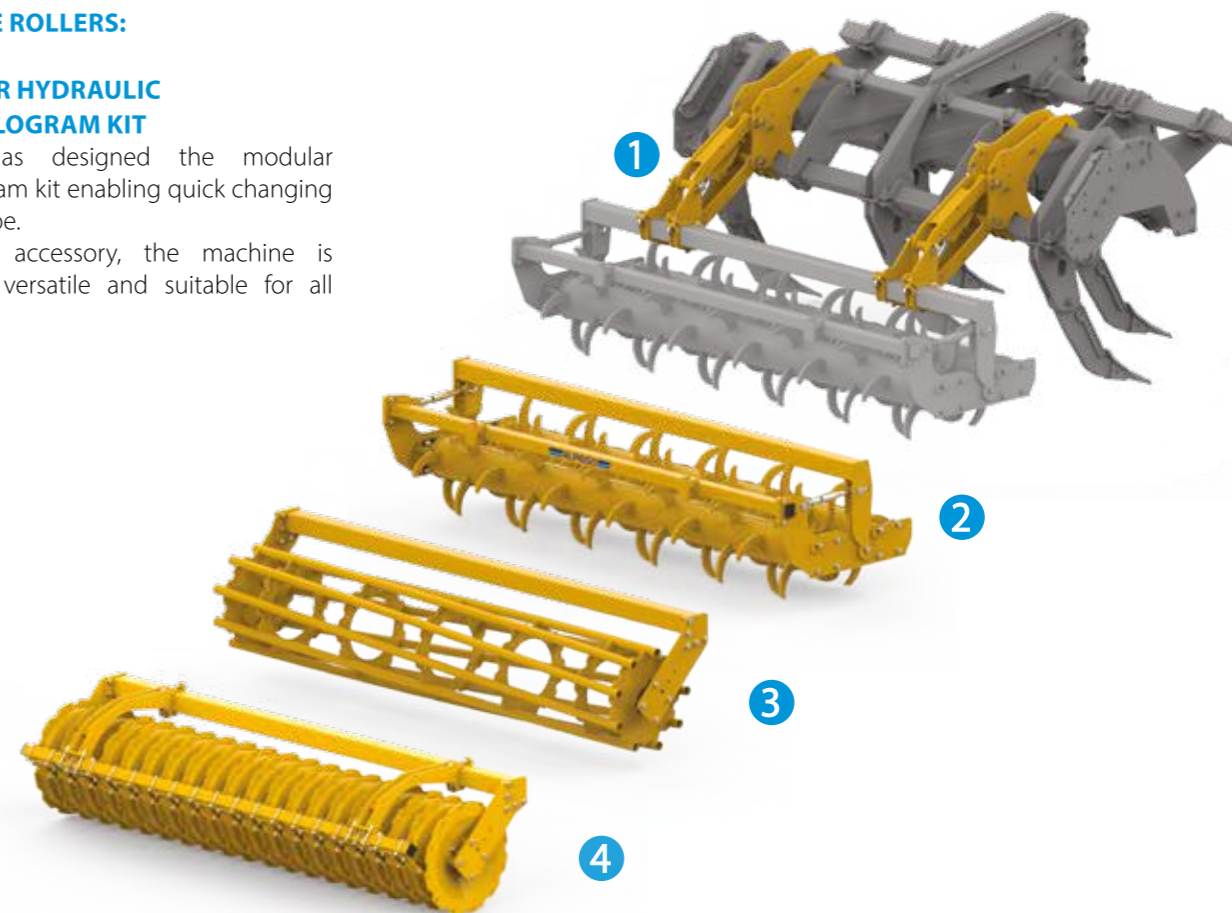

2 H50 FRANTER ROLLER

H50 FRANTER roller ideal for all soil types; floats over the soft soil but crumbles hard soils very effectively. Hydraulic depth adjustment. (Ø 220 mm)
Featured on the following models: K-EVO / K-FORCE / K-EXTREME / S1 / S2.

3 G6 CAGE ROLLER

CAGE G6 roller, ideal for dry, brittle and medium-density soils. (Ø 550 mm)
Featured on the following models: K-EVO / K-FORCE / K-EXTREME / S1 / S2.

4 DR6 DISC ROLLER

DR6 DISC roller suitable for very hard soils. (Ø 600 mm)
Featured on the following models: K-EVO / K-FORCE / K-EXTREME / S1 / S2.

AVAILABLE ROLLERS:



MECHANICAL FRANTER ROLLER M12

M12 FRANTER roller ideal for loose soil. (Ø 140 mm)
Mechanical depth adjustment.
Choice of two-point linkage (forward/rear), only for the Craker models.
Featured on the following models: K-DYNO / K-EVO / S1.



HYDRAULIC FRANTER ROLLER H12

H12 FRANTER roller ideal for loose soil. (Ø 140 mm)
Hydraulic depth adjustment.
Choice of two-point linkage (forward/rear), only for the Craker models.
Featured on the following models: K-DYNO / K-EVO / S1.



HYDRAULIC FRANTER ROLLER H22

H22 FRANTER roller also ideal for heavy soils. (Ø 194 mm)
Hydraulic depth adjustment.
Choice of two-point linkage (forward/rear), only for the Craker models.
Featured on the following models: K-EVO / K-FORCE / S1 / S2.



FRANter ROLLER K-EXTREME

H50 FRANTER roller (Ø 220 mm) ideal for all soils. Hydraulic depth adjustment with modular parallelogram that can also fit other types of roller (G6 / DR6).



CRAKER K-DYNO

DYNAMIC

Rigid mechanical subsoiler
for depths up to 51 cm

K-DYNO model is a compact, lightweight subsoiler that is still extremely rugged and dynamic thanks to the new frame design. Available in sizes 1.6 - 2 - 2.5 -3 m, it is recommended for use with tractors from 75 to 130 HP.

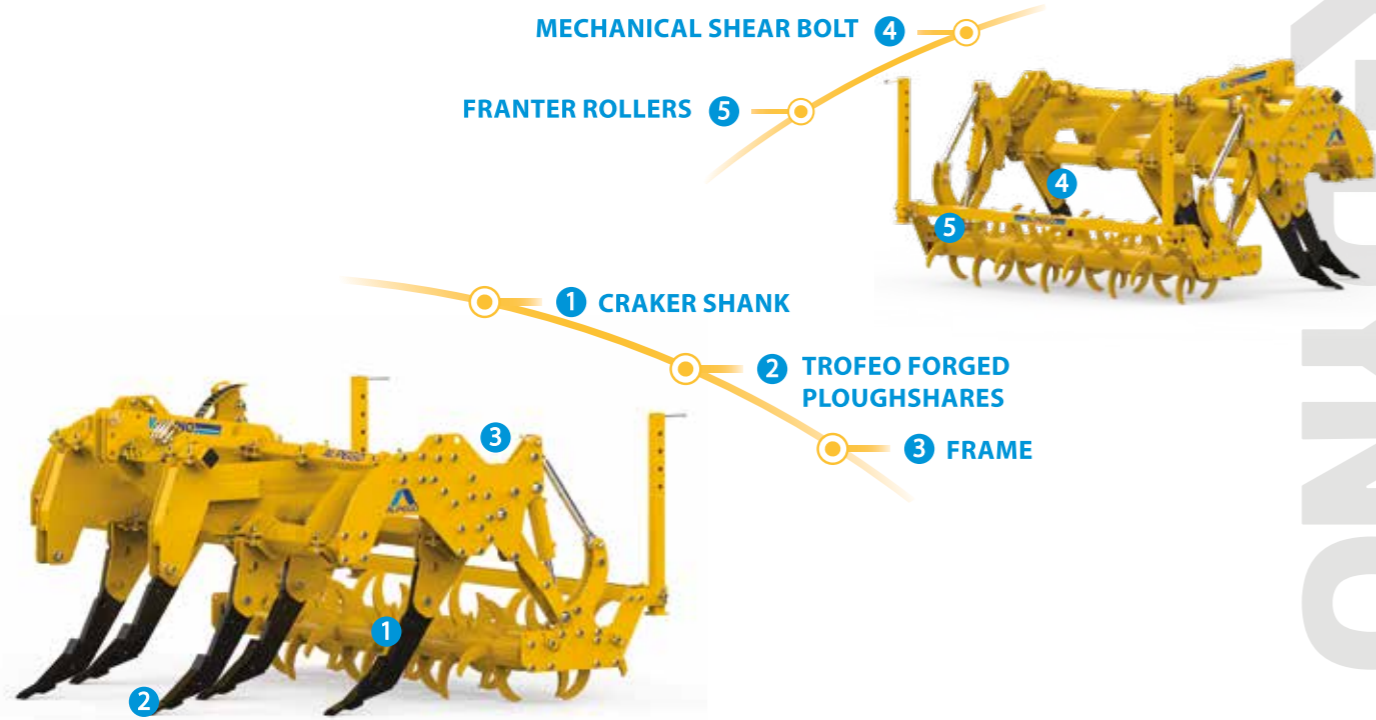

Model	CRAKER K-DYNO3-160	CRAKER K-DYNO5-200	CRAKER K-DYNO5-250	CRAKER K-DYNO7-250	CRAKER K-DYNO7-300
Working width (mm)	1600	2000	2500	2500	3000
Transport width (mm)	1575	2061	2480	2480	2975
Tractor power (HP)	75-130	75-130	85-130	95-130	105-130
Working depth (mm)	510	510	510	510	510
Shanks (no.)	3	5	5	7	7
Weight with mechanical Franter roller M12 (Kg)	840	990	1070	1160	1280
Weight with hydraulic Franter roller H12 (Kg)	830	1000	1090	1180	1290

1 CRAKER SHANK

Shank 30 mm thick with curved profile to reduce draft force and improve mixing.

3 FRAME

All-bolted frame in high strength steel with new design for higher performances.

2 TROFEO FORGED PLOUGHSHARES

Quick-removal ploughshares with variable thickness, reinforced tip and special steel structure.

4 MECHANICAL SHEAR BOLT

Safety bolt fitted on every shank; if the shank hits an obstacle, the bolt shears, protecting the machine's structure.

5 FRANTER ROLLERS

M12/H12 FRANTER rollers (Ø 140 mm)
Choice of two-point linkage (forward/rear).

EQUIPMENT

Linkage cat. 2 / Hardwearing shank guard / Diagonal shank fixing / Two support legs (mounted on roller).

CRAKER K-EVO

HIGH-PERFORMING

Rigid mechanical subsoiler
for depths up to 58 cm

K-EVO model subsoiler is intended for professional use, and is complete with ALFAST system.
Available in sizes 2.5 -3 - 3.5 m, recommended for tractors from 130 to 220 HP.

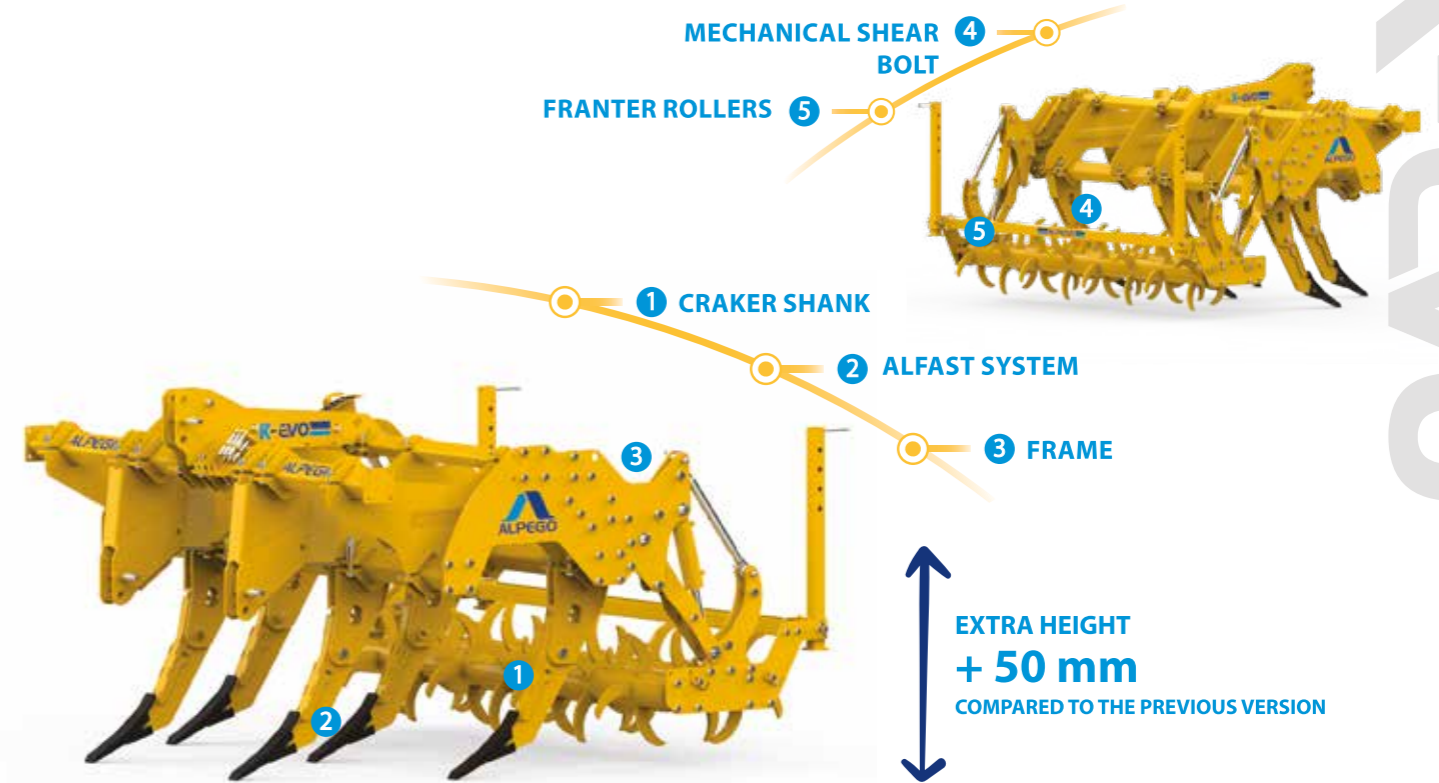

Model	CRAKER K-EVO 5-250	CRAKER K-EVO 7-300	CRAKER K-EVO 7-350
Working width (mm)	2500	3000	3500
Transport width (mm)	2505	3002	3494
Tractor power (HP)	130-220	160-220	160-220
Working depth (mm)	580	580	580
Shanks (no.)	5	7	7
Weight with mechanical Franter roller M12 (Kg)	1370	1570	-
Weight with hydraulic Franter roller H12 (Kg)	1390	1580	-
Weight with hydraulic Franter roller H22 (Kg)	1530	1750	1890

1 CRAKER SHANK

Shank 35 mm thick with curved profile to reduce draft force and improve mixing both in-depth on the surface.

3 FRAME

All-bolted frame in high strength steel with new design for higher performances.

2 ALFAST SYSTEM

TROFEO forged ploughshares and shank guards with ultra rapid fitting and removal system.

4 MECHANICAL SHEAR BOLT

Safety bolt fitted on every shank; if the shank hits an obstacle, the bolt shears, protecting the machine's structure.

5 FRANTER ROLLERS

FRANTER rollers M12/H12/H22 (Ø 140/220 mm) Choice of two-point linkage (forward/rear). Optional: Modular parallelogram kit.

EQUIPMENT

Linkage cat. 2 and 3 / Diagonal shank fixing / Clamp shock absorber on the front shanks / Two support legs (mounted on the roller).

CRAKER K-FORCE

TOP OF THE RANGE

Rigid mechanical subsoiler
for depths up to 65 cm

K-FORCE model subsoiler is intended for super-professional use, and is complete with ALFAST system and hydraulically adjusted roller as standard. Available in sizes 3-3.5-4m, recommended for tractors from 180 to 350 HP.

Mechanical subsoiler
K-FORCE

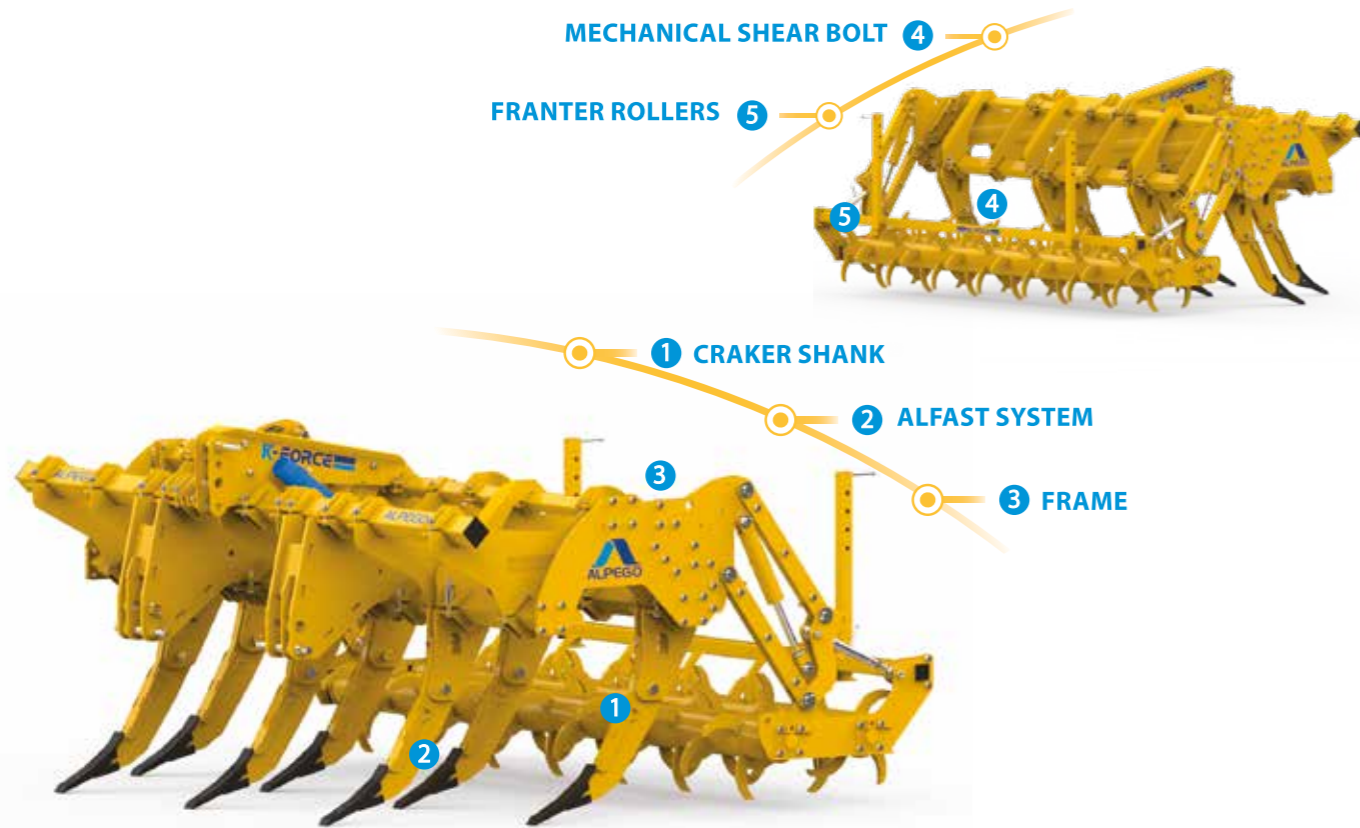

Model	CRAKER K-FORCE 7-300	CRAKER K-FORCE 7-350	CRAKER K-FORCE 9-400
Working width (mm)	3000	3500	4000
Transport width (mm)	3002	3495	3996
Tractor power (HP)	180-350	180-350	205-350
Working depth (mm)	650	650	650
Shanks (no.)	7	7	9
Weight with hydraulic Franter roller H22 (Kg)	2140	2290	2660
Weight with hydraulic Franter roller H50 (Kg)	2275	2415	2780
Weight with Cage Roller G6 (Kg)	2085	2135	-
Weight with Disc Roller DR6 (Kg)	2390	2520	-

1 CRAKER SHANK

Shank 35 mm thick with curved profile to reduce draft force and improve mixing both in-depth on the surface.

2 ALFAST SYSTEM

TROFEO forged ploughshares and shank guards with ultra rapid fitting and removal system.

3 FRAME

All-bolted frame in high strength steel with new design for higher performances.

4 MECHANICAL SHEAR BOLT

Safety bolt fitted on every shank; if the shank hits an obstacle, the bolt shears, protecting the machine's structure.

5 FRANTER ROLLERS

H22 FRANTER rollers (Ø 220 mm) Choice of two-point linkage (forward/rear) Optionals: Modular parallelogram kit.

EQUIPMENT

Linkage cat. 3, 4N, 3 USA and 4 USA / Diagonal shank fixing / Clamp shock absorber on all shanks / Two support legs (mounted on roller).



K-EXTREME

technical characteristics

The machine for extreme uses

K-EXTREME

Folding subsoiler with hydraulic closing system, available with 9 and 11 shanks, with transport width of just 2.60 m. The particularly rugged structure allows use in combination with very high powered tractors.



FOLDING FRAME

(Patented) hydraulic folding frame, 2.60 m wide during transport and working width 4.1 and 5 m.

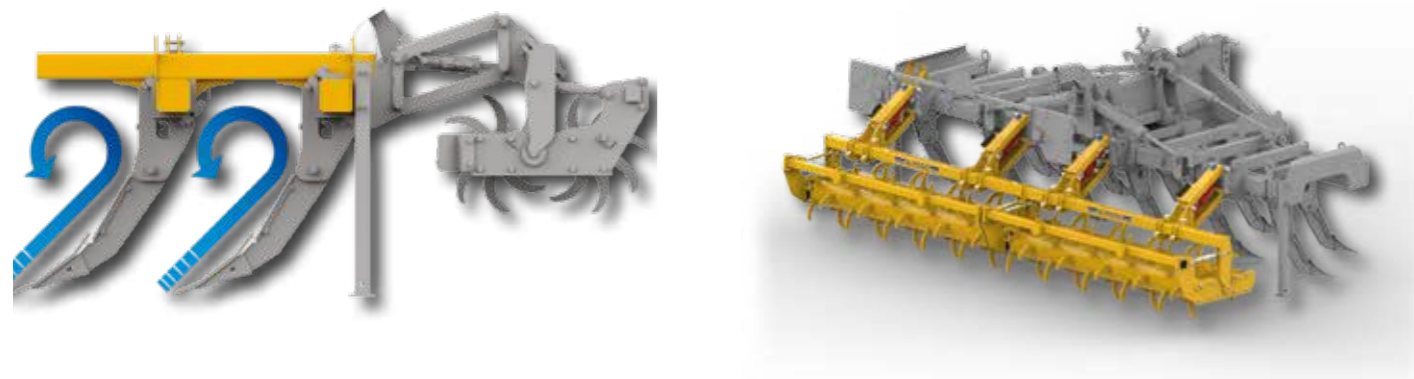

BRIDGE SOLUTION

Special frame solution introduced by Alpego to increase the clearance, which in contrast to conventional frames guarantees good soil flow at maximum working depth (up to 65 cm.)

HYDRAULIC CIRCUIT

Mega Craker subsoilers are equipped with roller with patented parallelogram system using a working depth control with a cross hydraulic circuit.

Folding subsoiler
Mega Craker K-EXTREME



MEGA CRAKER K-EXTREME

TOUGH

Folding mechanical subsoiler
for depths up to 65 cm

The Mega Craker K-EXTREME folding subsoiler is an extremely professional, top-of-the-range machine complete with ALFAST system and hydraulically adjusted roller as standard. Available in widths 4.1 and 5 m, it is designed for ultra-high powered tractors up to 500 HP.

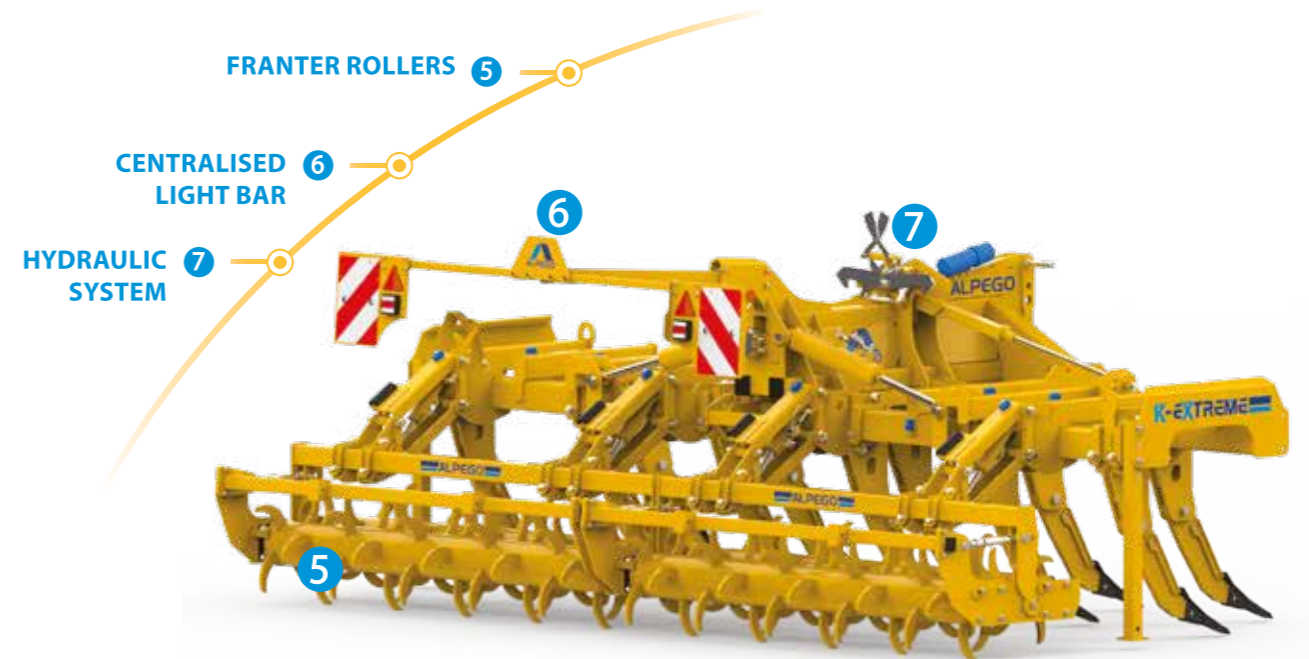
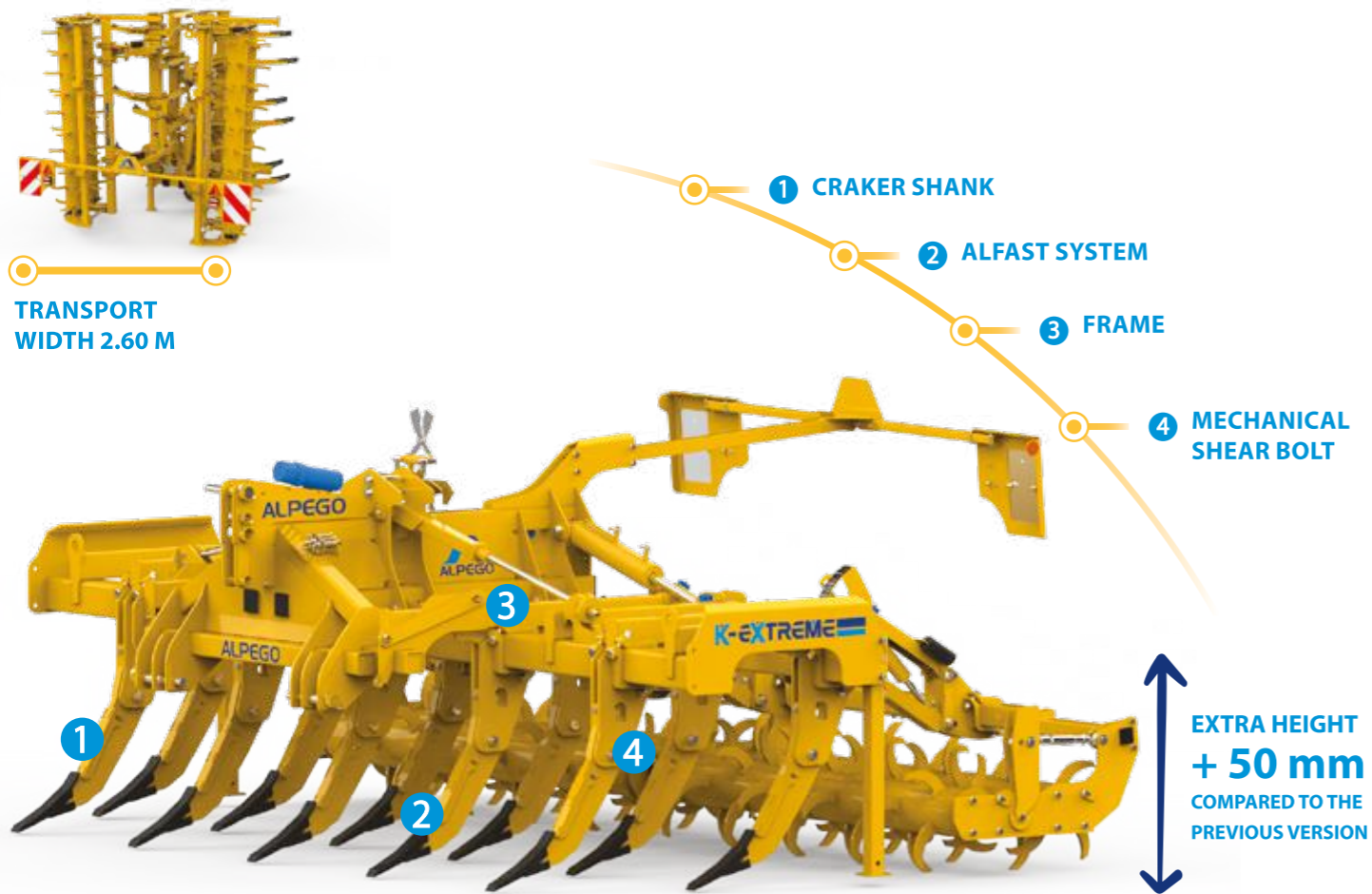

Model	K-EXTREME 9-410	K-EXTREME 11-500
Working width (mm)	4100	5000
Transport width (mm)	2600	2600
Tractor power (HP)	250-500	350-500
Working depth (mm)	650	650
Shanks (no.)	9	11
Weight with hydraulic Franter roller H50 (Kg)	3460	3810

1 CRAKER SHANK
Shank 35 mm thick with curved profile to reduce draft force and improve mixing both in-depth on the surface.

3 FRAME
High performance all-bolted frame in high strength steel. Hydraulic closure with transport width 2.60 m.

4 MECHANICAL SHEAR BOLT
Safety bolt fitted on every shank; if the shank hits an obstacle, the bolt shears, protecting the machine's structure.

2 ALFAST SYSTEM
TROFEO forged ploughshares and shank guards with ultra rapid fitting and removal system.

5 FRANTER ROLLERS
H50 FRANTER roller (Ø 220 mm) ideal for all soils. Hydraulic depth adjustment with modular parallelogram that can also fit other types of roller (G6 / DR6).

6 CENTRALISED LIGHT BAR
Centralised lights bar, compete with reflective side tables and LED lighting as standard.

7 HYDRAULIC SYSTEM
Closing mechanism with hydraulic system, automatic release and safety hooks.

EQUIPMENT
Linkage cat. 3, 4, 3 USA, 4 USA and 4N USA / TROFEO quick-fitting ploughshares / Hard-wearing shank guard / Double support leg (roller mounted) / Reflective side tables with rear lights.

K-EXTREME

SKAT technical characteristics

Hydro-pneumatic system

HYDRAULIC NO STOP

The system, comprising a nitrogen accumulator with regulator valve and a series of cylinders, one on each shank, enables the shanks to absorb shocks and stresses and return to place gradually, avoiding damage to the frame structure.

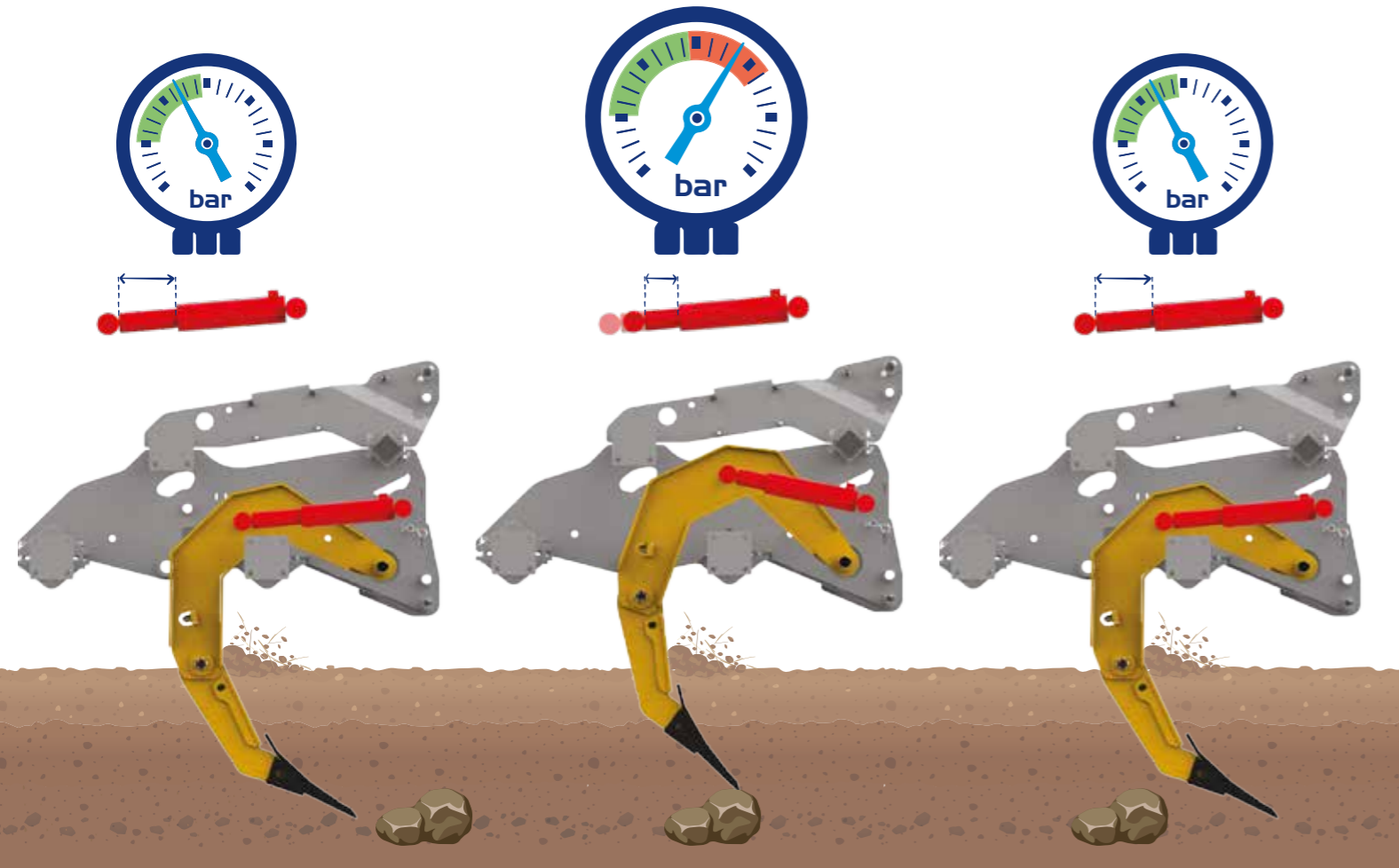

ROCK SHANK (for very stony ground)

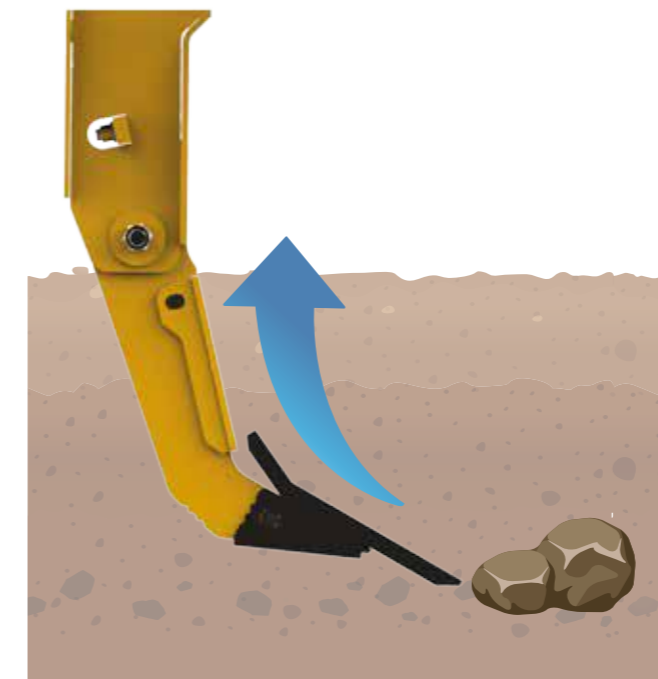

ROCK SHANK

Rock shank with reinforced hardwearing ploughshares, to overcome obstacles in very stony ground. The unusual angle prevents stones from being dragged to the surface.

CRAKER SHANK (for heavy ground)

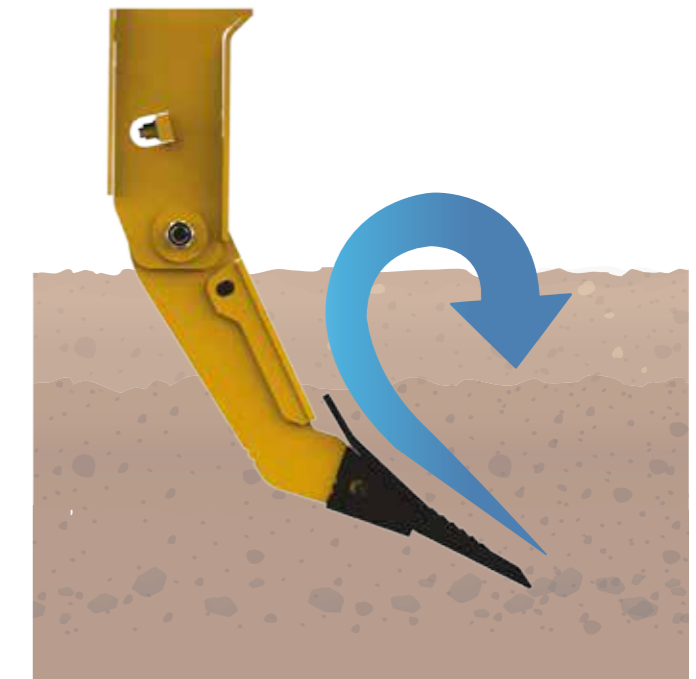

CRAKER SHANK

Suitable on heavy soils without too many stones. When combined with the SKAT hydro-pneumatic system, they provide excellent elasticity, meaning a longer machine lifetime and less stress on the tractor.

SHEAR BOLT

In addition to the hydraulic NO STOP system, each shank is fitted with an easily replaceable shear bolt which breaks in case of excessive stresses to safeguard the machine's structure.

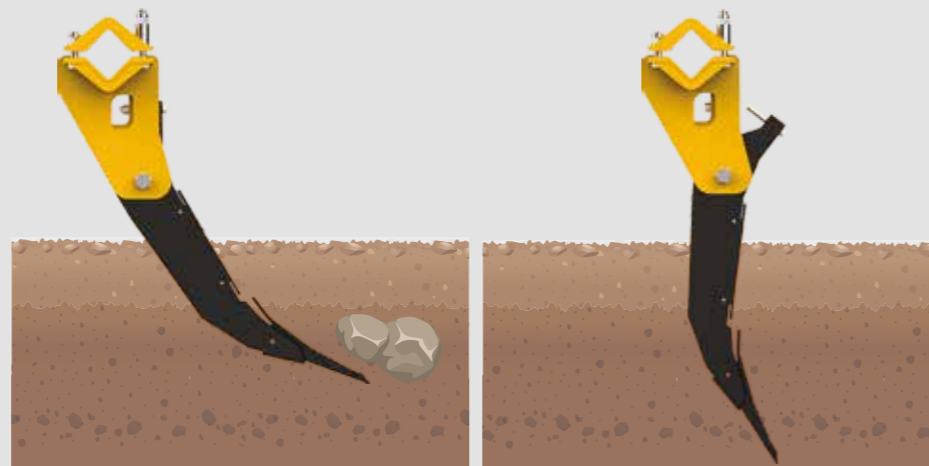

BOLTED FRAME

High performance all-bolted frame. New side plate design for faster roller mounting. The high strength steel used provides the optimal trade-off between light weight and resistance.

Standard on models: S1 / S2



SKAT S1

CUTTING-EDGE

Hydro-pneumatic subsoiler for depths up to 58 cm

S1 hydro-pneumatic subsoiler, professional machine available with two Franter rollers with mechanical or hydraulic adjustment. Constructed in high-tensile steel and available in 3 different working widths of 2.5 - 3 - 3.5 m, it is ideal for tractors from 130 to 250 HP.

SKAT S2

STRONG

Hydro-pneumatic subsoiler for depths up to 65 cm

S2 model hydro-pneumatic subsoiler, super-professional, rugged machine available with two Franter rollers with hydraulic adjustment. Constructed entirely in high strength steel and available in no less than 3 different working widths of 3 - 3.5 and 4 m, it is ideal for tractors from 220 to 400 HP.

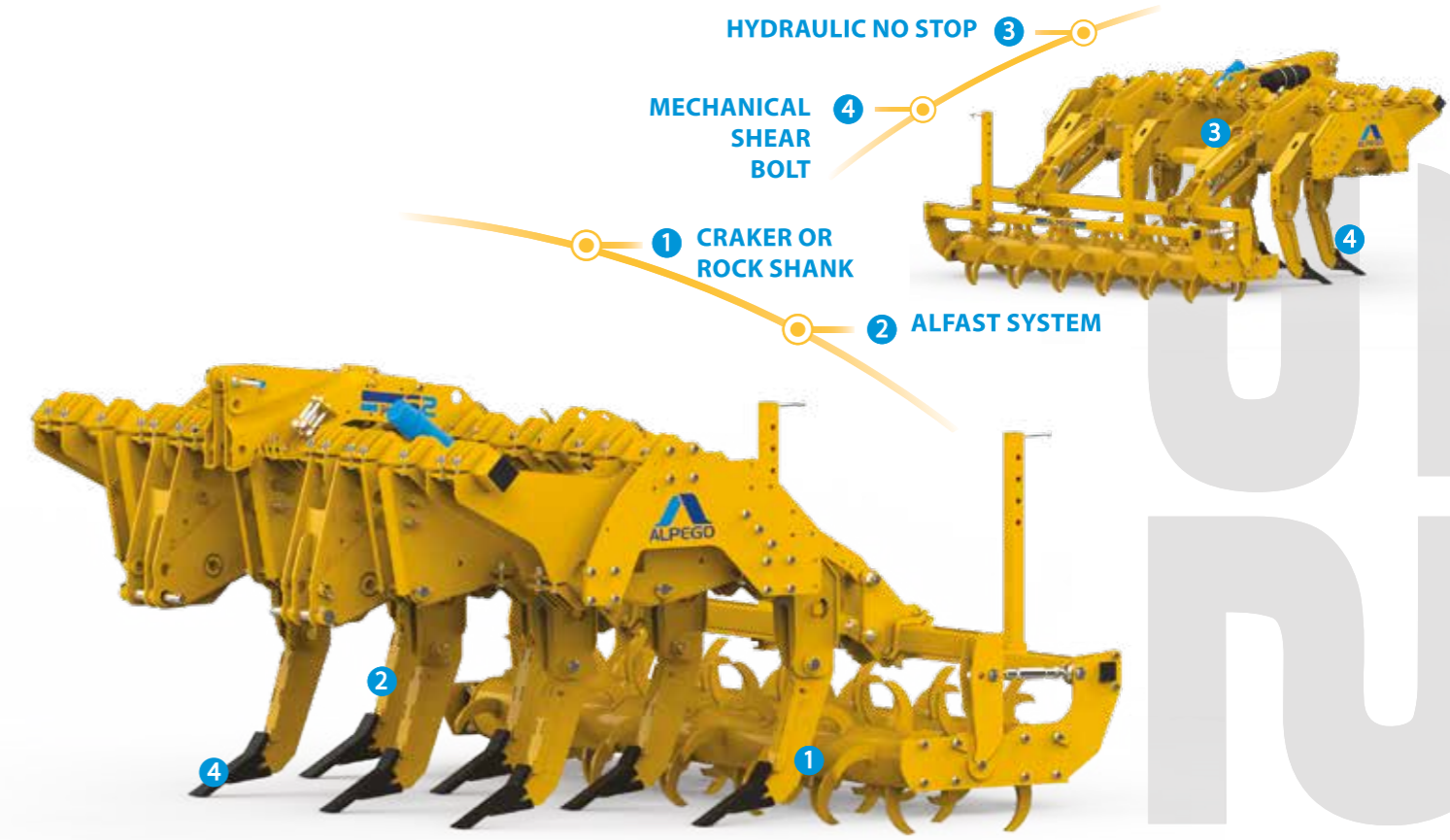
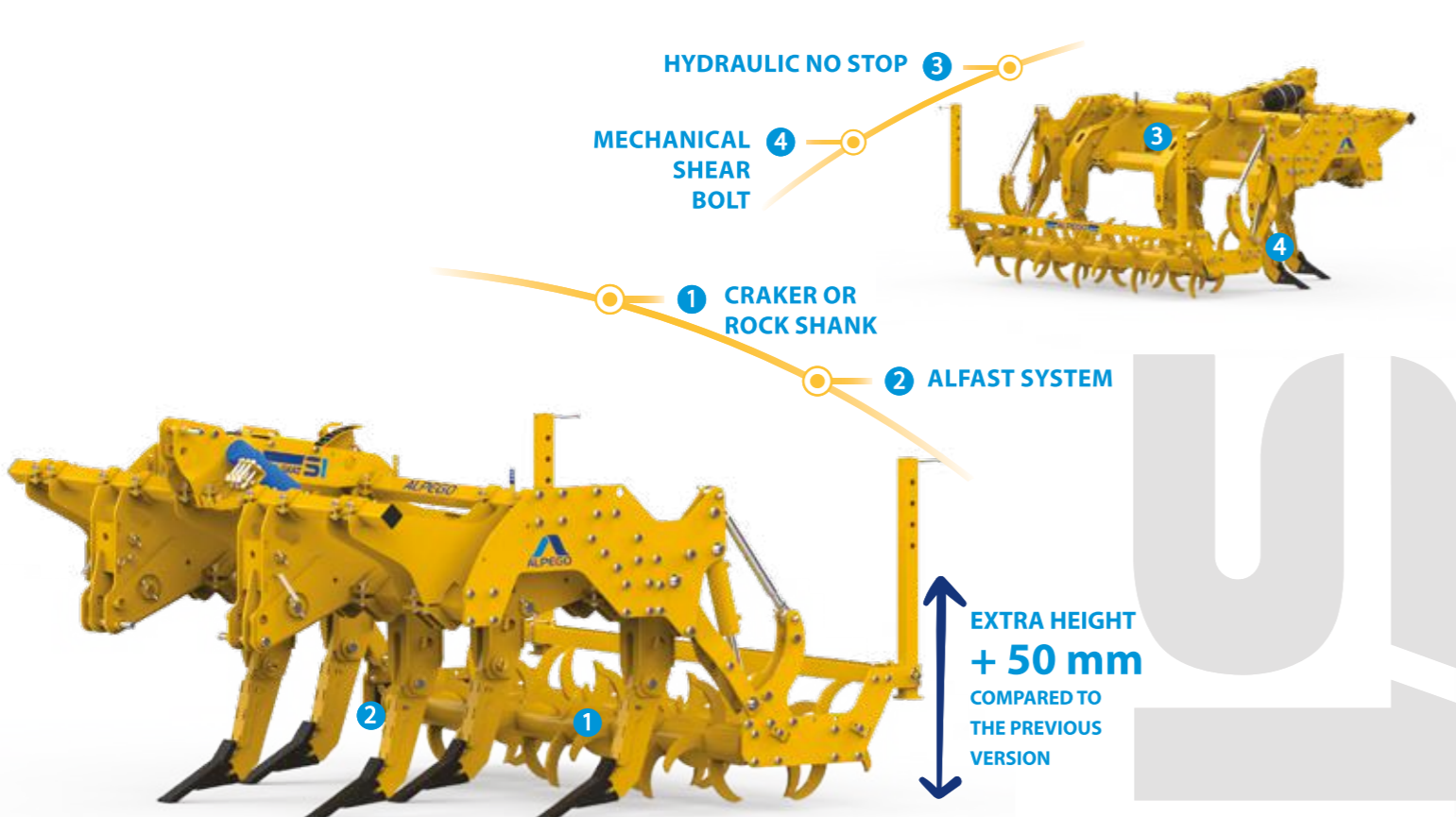

Model	SKAT S1 5-250	SKAT S1 7-300	SKAT S1 7-350
Working width (mm)	2500	3000	3500
Transport width (mm)	2505	3002	3495
Tractor power (HP)	130-250	140-250	140-250
Working depth (mm)	580	580	580
Shanks (no.)	5	7	7
Weight with mechanical Franter roller M12 + shank (Kg)	1555	1915	-
Weight with hydraulic Franter roller H12 + shank (Kg)	1575	1925	-
Weight with hydraulic Franter roller H22 + shank (Kg)	1715	2095	2240

Model	SKAT S2 7-300	SKAT S2 7-350	SKAT S2 9-400
Working width (mm)	3000	3500	4000
Transport width (mm)	3002	3495	3996
Tractor power (HP)	220-400	220-400	270-400
Working depth (mm)	650	650	650
Shanks (no.)	7	7	9
Weight with hydraulic Franter roller H22 + shank (Kg)	2720	2880	3255

1 CRAKER OR ROCK SHANK
35 mm shank available in two different types to suit many needs.

2 ALFAST SYSTEM
TROFEO forged ploughshares and shank guards with ultra rapid fitting and removal system.

3 HYDRAULIC NO STOP
The system, comprising a nitrogen accumulator with regulator valve and a series of cylinders, one on each shank, enables the shanks to absorb shocks and stresses and return to place gradually, avoiding damage to the frame structure.

4 MECHANICAL SHEAR BOLT
Safety bolt fitted on every shank; if the shank hits an obstacle, the bolt shears, protecting the machine's structure.

EQUIPMENT
Linkage cat. 2 and 3 / Two support legs (mounted on the roller).

1 CRAKER OR ROCK SHANK
35 mm shank available in two different types to suit many needs.

2 ALFAST SYSTEM
TROFEO forged ploughshares and shank guards with ultra rapid fitting and removal system.

3 HYDRAULIC NO STOP
The system, comprising a nitrogen accumulator with regulator valve and a series of cylinders, one on each shank, enables the shanks to absorb shocks and stresses and return to place gradually, avoiding damage to the frame structure.

4 MECHANICAL SHEAR BOLT
Safety bolt fitted on every shank; if the shank hits an obstacle, the bolt shears, protecting the machine's structure.

EQUIPMENT
Linkage cat. 3, 3 USA and 4N / Two support legs (mounted on the roller).

Choosing the ploughshare

The right ploughshare for every situation



TROFEO



Trofeo ploughshare, with an exclusive design, variable thickness and reinforced tip and forged special steel structure, increases the useful life by 20%. The grooves in the upper face of the ploughshare fill with soil and consequently reduce wear thanks to the soil-soil contact.

TROFEO WEARPROOF



WEARPROOF ploughshare with special hard-wearing surface treatment to guarantee a prolonged life and optimal working performance for much longer than the standard version.

TROFEO PLUS



TROFEO PLUS ploughshare with a special Tungsten carbide plates positioned on the tip. This ploughshare is recommended for use in very tough, heavy-duty conditions. The plate enables the tip to preserve its effective length over time, ensuring greater maintenance of the working depth compared to standard ploughshares.

Ploughshares	K-DYNO	K-EVO	K-FORCE	K-EXTREME	S1	S2
TROFEO	ALFAST	ALFAST	ALFAST	ALFAST	ALFAST	ALFAST
TROFEO WEARPROOF	ALFAST	ALFAST	ALFAST	ALFAST	ALFAST	ALFAST
TROFEO PLUS	ALFAST	ALFAST	ALFAST	ALFAST	ALFAST	ALFAST

Choosing the accessory

The right accessory for every situation



CLOD-SHATTERING FINS



DEK PLOUGHSHARE



PAIR OF REAR WHEELS



TELESCOPIC CLOD-RESTRICTING SIDE BOARDS



REFLECTIVE SIDE TABLES WITH REAR LIGHTS



REAR ROLLER

Accessories and rollers	K-DYNO	K-EVO	K-FORCE	K-EXTREME	S1	S2
Clod-shattering fins	ALFAST	ALFAST	ALFAST	ALFAST	ALFAST	ALFAST
DEK ploughshare	ALFAST	ALFAST	ALFAST	ALFAST	ALFAST	ALFAST
Pair of rear wheels						
Telescopic clod-restricting side boards						
Reflective side tables with rear lights						
M12 Mechanical Franter Roller						
H12 Hydraulic Franter Roller						
H22 Hydraulic Franter Roller						
H50 Hydraulic Franter Roller						
G6 Cage Roller						
DR6 Disc Roller						

Accessory

Standard

Not available

FOLDABLE POWER HARROWS

120 - 500 HP



RIGID POWER HARROWS

35 - 320 HP



SUBSOILERS

75 - 500 HP



ROTARY TILLERS AND STONE BURIERS

75 - 500 HP



SEED DRILLS

75 - 320 HP



FRONT HOPPERS

120 - 500 HP



CULTIVATORS

120 - 300 HP



FLAIL MOWERS

40-220 HP



H-7522 Kaposújlak, 095/3 hrsz.
Tel: +36-82/713-274, +36-30/336-9804
E-mail: bedenek@kapos-net.hu
WEB: www.bedenek.hu